

PERFORMANCE AND ENVIRONMENTAL LIFE CYCLE ANALYSIS OF THERMOSYPHON SOLAR WATER HEATERS

Soteris Kalogirou

Higher Technical Institute, P. O. Box 20423, Nicosia 2152, Cyprus
Tel. +357-22-406466, Fax: +357-22-494953, Email: skalogir@spidernet.com.cy

ABSTRACT

One of the most widely used systems for domestic water heating is the solar thermosyphon unit. A thermosyphon system, suitable for Mali, consists of one flat-plate collector panel 1.35m^2 in aperture area and a 150 lt hot water cylinder. No pump is required for this system as the hot water is transferred to storage because of the thermosyphon effect. The system is modelled and simulated with TRNSYS program for Bamako, Mali and the results show that 6,648 MJ of energy can be provided per year and the solar contribution is 0.96, i.e., 96% of the needs for hot water for a 4-6 persons family are satisfied with solar energy. The financial characteristics of the system investigated give positive and very promising figures. By considering a rate for electricity equal to 0.16 US\$/kWh, the pay back time is 2 years and the life cycle savings, representing the money saved because of the use of the system throughout its life (20 years) instead of using conventional energy (electricity), is US\$ 2,200. With respect to the life cycle assessment, the pollution created for the production of the system is estimated by calculating the embodied energy invested in the manufacture, assembly and installation of the collectors and other parts of the system. For the present thermosyphon system the embodied energy is found to be equal to 4,283 MJ. By considering the useful energy collected by the system each year, the embodied energy is recouped in about 8 months. It can therefore be concluded that solar energy systems offer significant protection to the environment and cost savings and should be employed whenever possible in order to achieve a sustainable future.

1. INTRODUCTION

Energy is considered a prime agent in the generation of wealth and a significant factor in economic development. The importance of energy in economic development is recognised universally and historical data verify that there is a strong relationship between the availability of energy and economic activity. Although at the early seventies, after the oil crisis, the concern was on the cost of energy, during the past two decades the risk and reality of environmental degradation have become more apparent. The growing evidence of environmental problems is due to the increase of the world population, energy consumption and industrial activities. Achieving solutions to environmental problems that humanity faces today requires long-term potential actions for sustainable development. In this respect, renewable energy resources appear to be one of the most efficient and effective solutions.

A few years ago, most environmental analysis and legal control instruments concentrated on conventional pollutants such as sulphur dioxide (SO_2), nitrogen oxides (NO_x), particulates, and carbon monoxide (CO). Recently however, environmental concern has extended to the control of hazardous air pollutants, which are usually toxic chemical substances which are harmful even in small doses, as well as to other globally significant pollutants such as carbon dioxide (CO_2).

One of the most widely accepted definitions of sustainable development is: “*development that meets the needs of the present without compromising the ability of future generations to meet their own needs*”. There are many factors that can help to achieve sustainable development. Today, one of the main factors that must be considered in discussions of sustainable development is energy and one of the most important issues is the requirement for a supply of energy that is fully sustainable [1, 2]. A secure supply of energy is a necessary but not a sufficient requirement for development within a society. Such a supply in the long term should be readily available at reasonable cost, be sustainable and be able to be utilized for all the required tasks without causing negative societal impacts. This is why there is a close connection between renewable sources of energy and sustainable development.

Today the world daily oil consumption is 76 million barrels. Despite the well known consequences of fossil fuel combustion on the environment, this is expected to increase to 123 million barrels per day by the year 2025 [3].

The principal objective of this paper is to present a description of the constructional and thermal characteristics of thermosyphon units. This is followed by a study on the performance characteristics and environmental protection offered by the systems.

2. ENVIRONMENTAL IMPACT OF CONVENTIONAL ENERGY SOURCES

Pollution depends on energy consumption. There are a large number of factors which are significant in the determination of the future level of the energy consumption and production. Such factors include population growth, economic performance, consumer tastes and technological developments. Furthermore, governmental policies concerning energy and developments in the world energy markets will certainly play a key role in the future level and pattern of energy production and consumption. During the last two decades, environmental considerations have been given increasing attention by energy industries and the public and the concept that due to irrational use consumers share responsibility for pollution and its cost has been increasingly accepted. In some cases, the prices of some energy resources have increased over the last one to two decades, in order to account for environmental costs [4].

Another parameter to be considered is the world population. This is expected to double by the middle of this century and as economic development will certainly continue to grow, the global demand for energy is expected to increase. At the same time, concern regarding energy-related environmental pollution will increase.

Problems associated with energy supply and use are related not only to global warming, but also to other environmental impacts such as air pollution, acid precipitation, ozone depletion, forest destruction and emission of radioactive substances [4]. Today much evidence exists, which suggests that the future of our planet and of the generations to come will be negatively impacted if humans keep degrading the environment. The three major environmental problems that are internationally known are acid rain, ozone layer depletion and global climate change.

3. RENEWABLE ENERGY TECHNOLOGIES

Renewable energy technologies produce marketable energy by converting natural phenomena such as sunshine and wind into useful forms of energy. Renewable energy sources have massive energy potential, however, they are generally diffused and not fully accessible, most

of them are intermittent, and have distinct regional variabilities. These characteristics give rise to difficult, but solvable, technical and economical challenges. Nowadays, significant progress is made by improving the collection and conversion efficiencies, lowering the initial and maintenance costs, and increasing the reliability and applicability.

Several potential solutions to the current environmental problems associated with the harmful pollutant emissions from the burning of fossil fuels have evolved, including renewable energy and energy conservation technologies. Many countries consider today solar, wind and other renewable energy technologies as the key to a clean energy future. A worldwide research and development in the field of renewable energy resources and systems is carried out during the last two decades. Energy conversion systems that are based on renewable energy technologies appeared to be cost effective compared to the projected high cost of oil. Furthermore, renewable energy systems can have a beneficial impact on the environmental, economic, and political issues of the world.

The benefits arising from the installation and operation of renewable energy systems can be distinguished into three categories; energy saving, generation of new working posts and the decrease of environmental pollution [5].

The energy saving benefit derives from the reduction in consumption of the electricity and/or diesel which are used conventionally to provide energy. This benefit can be directly translated into monetary units according to the corresponding production or avoiding capital expenditure for the purchase of imported fossil fuels.

One area which seems to be of considerable importance in many countries is the ability of renewable energy technologies to generate jobs as a means of economic development to a country. The penetration of a new technology leads to the development of new production activities contributing to the production, market distribution and operation of the pertinent equipment. Specifically in the case of solar energy collector, job creation mainly relates to the construction and installation of the collectors. The latter is a decentralised process since it requires the installation of equipment in every building or every individual consumer.

The most important benefit of renewable energy systems is the decrease of environmental pollution. This is achieved by the reduction of air emissions due to the substitution of electricity and conventional fuels. The most important effects of air pollutants on the human and natural environment are their impact on the public health, agriculture, buildings and ecosystems [5]. It is relatively simple to measure the financial impact of these effects when they relate to tradable goods such as the agricultural crops; however when it comes to non-tradable goods like human health and ecosystems things becomes more complicated. It should be noted that the level of the environmental impact and therefore the social pollution cost largely depends on the geographical location of the emission sources. In this paper emphasis is given to solar thermosyphon systems. These are very popular systems used extensively in many countries with good sunshine potential.

4. THERMOSYPHON SOLAR WATER HEATER

Thermosyphon systems, shown in Fig. 1, heat potable water or heat transfer fluid and use natural convection to transport it from the collector to storage. The water in the collector expands becoming less dense as the sun heats it and rises through the collector into the top of the storage tank. There it is replaced by the cooler water that has sunk to the bottom of the tank, from which

it flows down the collector. Circulation continuous as long as there is sunshine. Since the driving force is only a small density difference larger than normal pipe sizes must be used to minimise pipe friction. Connecting lines must be well insulated to prevent heat losses and sloped to prevent formation of air pockets which would stop circulation. At night, or whenever the collector is cooler than the water in the tank the direction of the thermosyphon flow will reverse, thus cooling the stored water. One way to prevent this is to place the top of the collector well below (about 30cm) the bottom of the storage tank.

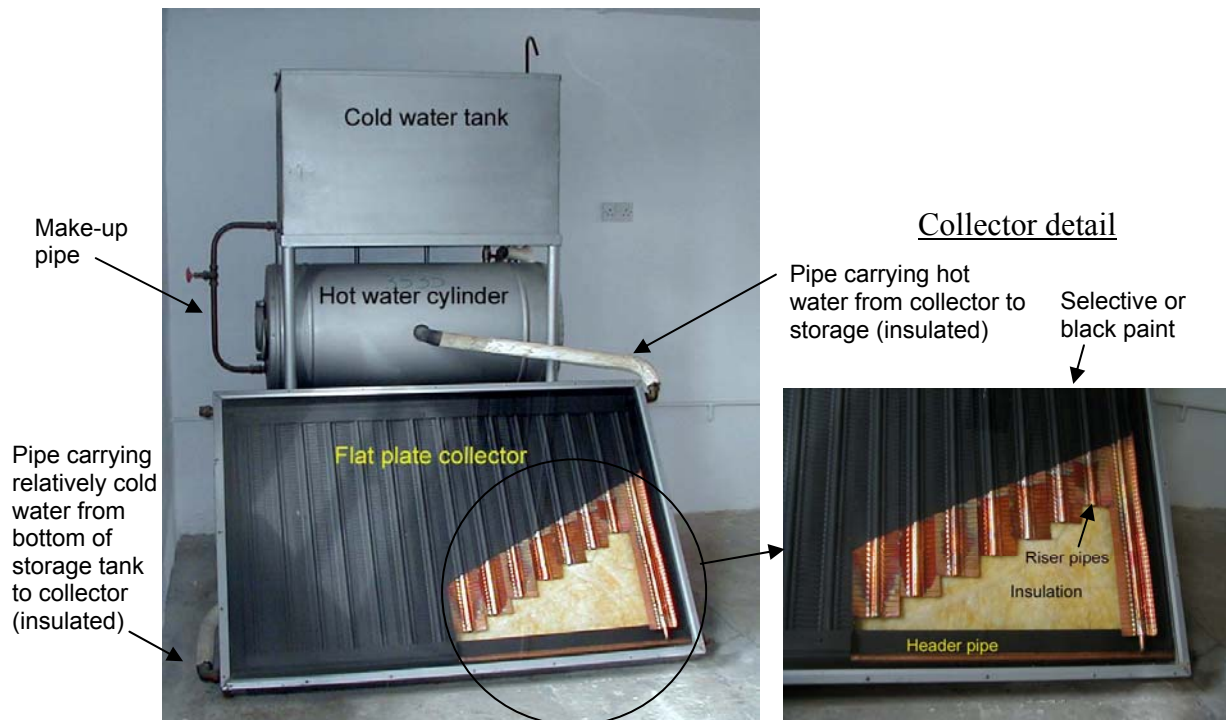

Fig. 1 Photo of a laboratory model thermosyphon solar water heater

The main disadvantage of thermosyphon systems is the fact that they are comparatively tall units, which makes them not very attractive aesthetically. Usually, a cold water storage tank is installed on top of the solar collector, supplying both the hot water cylinder and the cold water needs of the house, thus making the collector unit taller and even less attractive. Additionally, extremely hard or acidic water can cause scale deposits that clog or corrode the absorber fluid passages. For direct systems, pressure-reducing valves are required when the city water is used directly (no cold water storage tank) and pressure is greater than the working pressure of the collectors.

The usual type of collector employed in thermosyphon units is the flat-plate. A typical flat-plate solar collector is shown in Fig. 2. When solar radiation passes through a transparent cover and impinges on the blackened absorber surface of high absorptivity, a large portion of this energy is absorbed by the plate and then transferred to the transport medium (water) in the fluid tubes to be carried away for storage or use. The underside of the absorber plate and the side of casing are well insulated to reduce conduction losses. The liquid tubes can be welded to the absorbing plate, or they can be an integral part of the plate. The liquid tubes are connected at both ends by large diameter header tubes.

The transparent cover is used to reduce convection losses from the absorber plate through the restraint of the stagnant air layer between the absorber plate and the glass. It also reduces radiation losses from the collector as the glass is transparent to the short wave radiation

received by the sun but it is nearly opaque to long-wave thermal radiation emitted by the absorber plate (greenhouse effect).

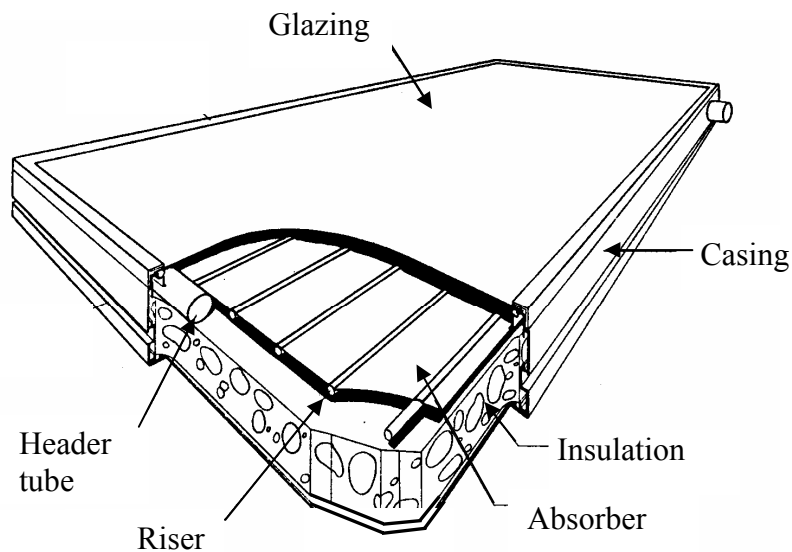

Fig. 2 Pictorial view of a flat-plate collector

Flat plate collectors are usually permanently fixed in position and require no tracking of the sun. The collectors should be oriented directly towards the equator, facing south in the northern hemisphere and north in the southern. The optimum tilt angle of the collector is equal to the latitude of the location with angle variations of 10° to 15° more or less depending on the application [6].

A flat-plate collector generally consists of the following components as shown in Fig. 3:

Glazing. Glass or other diathermanous (radiation-transmitting) material.

Tubes, fins, or passages. To conduct or direct the heat transfer fluid from the inlet to the outlet.

Absorber plates. Flat, corrugated, or grooved plates, to which the tubes, fins, or passages are attached. The plate may be integral with the tubes.

Headers or manifolds. To admit and discharge the fluid.

Insulation. To minimise the heat loss from the back and sides of the collector.

Container or casing. To surround the aforementioned components and keep them free from dust, moisture, etc.

Flat-plate collectors have been built in a wide variety of designs and from many different materials. They have been used to heat fluids such as water, water plus antifreeze additive, or air. Their major purpose is to collect as much solar energy as possible at the lower possible total cost. The collector should also have a long effective life, despite the adverse effects of the sun's ultraviolet radiation, corrosion and clogging because of acidity, alkalinity or hardness of the water, freezing of water, or deposition of dust or moisture on the glazing, and breakage of the glazing because of thermal expansion, hail, vandalism or other causes. These causes can be minimised by the use of tempered glass.

For fluid-heating collectors, passages must be integral with or firmly bonded to the absorber plate. A major problem is obtaining a good thermal bond between tubes and absorber plates

without incurring excessive costs for labour or materials. Material most frequently used for collector plates are copper, aluminium, and stainless steel.

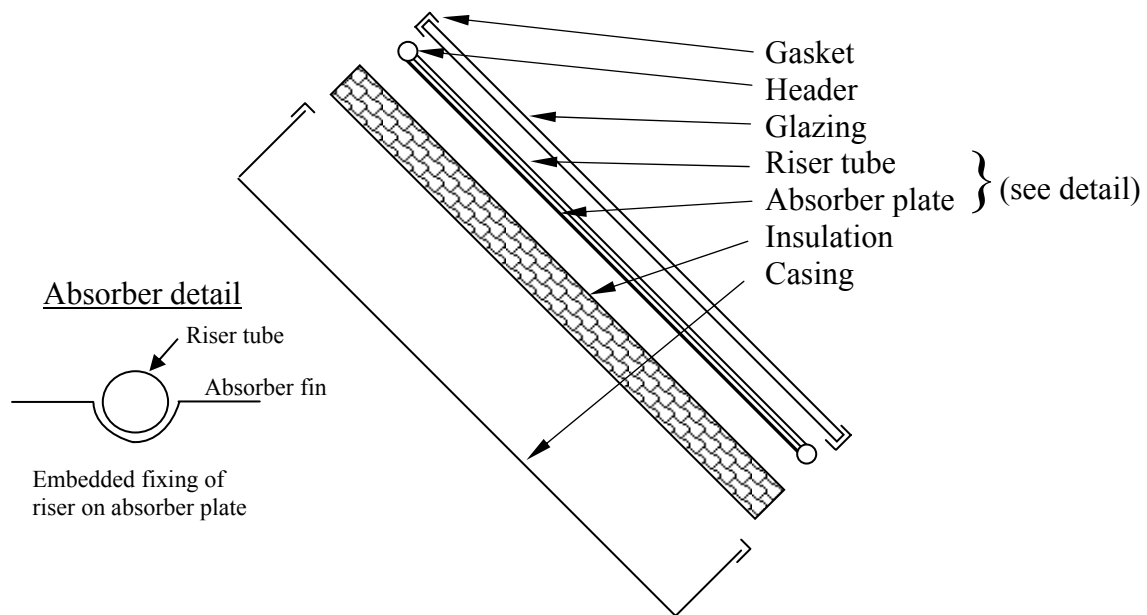

Fig. 3 Exploded view of a flat-plate collector and absorber detail

Flat plate collectors are by far the most used type of collector. Flat-plate collectors are usually employed for low temperature applications up to 100°C, although some new types of collectors employing vacuum insulation and/or transparent insulation (TI) can achieve slightly higher values. The characteristics of the flat plate collector considered in this study are shown in Table 1 whereas the characteristics of the thermosyphon system are shown in Table 2.

Table 1 Characteristics of a the flat plate collector considered here

Parameter	Characteristics
Riser pipe diameter	15mm
Header pipe diameter	28mm
Absorber plate thickness	0.5mm
Insulation material	Fiber wool
Insulation thickness	40mm
Fixing of risers on the absorber plate	Embedded
Absorber coating	Black mat paint
Glazing	Low-iron glass
External casing material	Galvanized sheet
External casing thickness	0.5mm

5. PERFORMANCE CHARACTERISTICS OF SOLAR WATER HEATER

In order to evaluate its performance characteristics the system is modelled with TRNSYS program [7]. TRNSYS is an acronym for a “transient simulation program” and is a quasi-steady simulation model. The program consists of many subroutines that model subsystem components. The mathematical models for the subsystem components are given in terms of their ordinary differential or algebraic equations. TRNSYS has the capability of

interconnecting system components in any desired manner, solving differential equations and facilitating information output. Thermosyphon systems are modelled with Type 45 in which the collector characteristics shown in Table 2 are required together with various dimensions of the system.

Table 2 Characteristics of the thermosyphon system

Parameter	Characteristics of collector
Collector area	1.35 m ²
Storage tank volume	150 lt
Efficiency mode	$n v_s (T_i - T_a)/G$
G_{test} – flow rate per unit area at test conditions (kg/s-m ²)	0.015
I – intercept efficiency	0.79
S – negative slope of the first-order coefficient of the efficiency (W/m ² °C)	6.67
b_o – incidence angle modifier constant	0.1
Collector slope angle (Latitude +5-10°)	20°

TRNSYS is employing the standard collector performance equation in which the intercept (I) and slope (S) factors, shown in Eq. 1, are used to model the collector.

$$n = K_{\alpha\tau} I - S \frac{\Delta T}{G} \quad (1)$$

where G is the global solar radiation, $k_{\alpha\tau}$ is the incidence angle modifier and ΔT is equal to $T_i - T_a$, i.e. inlet temperature to the collector minus ambient temperature. TRNSYS employs the following model for the incidence angle modifier:

$$k_{\alpha\tau} = 1 - b_o \left(\frac{1}{\cos(\theta)} - 1 \right) \quad (2)$$

where b_o is a constant and θ is the angle of incidence. The useful energy extracted from the collectors is given by:

$$Q_u = F_R A [k_{\alpha\tau} (\tau\alpha) G - U_L (T_i - T_a)] \quad (3)$$

where F_R is the heat removal factor, A is the collector area, $\tau\alpha$ is the transmittance-absorptance product and U_L is the collector heat loss coefficient.

The total useful energy for the whole year is obtained from:

$$Q_{u,a} = \sum_{d=1}^{365} \sum_{h=1}^{24} Q_u \quad (4)$$

and the auxiliary energy required, Q_{aux} is:

$$Q_{\text{aux}} = Q_{\text{load}} - [Q_{u,a} - Q_{\text{loss}}] \quad (5)$$

where Q_{load} is the energy required by the load and Q_{loss} is the energy lost from the storage tank.

As can be seen from the above equations the energy obtained from the solar collector field depends on the inlet temperature to the collector T_i , which depends on the load pattern and the losses from the storage tank.

5.1 Weather data used in simulations

Usually solar systems are simulated with Typical Meteorological Year (TMY) data. As no such data are available for Mali mean monthly values were used with a special TRNSYS routine (Type 54) which produces the required data. The data required are the mean monthly solar global radiation on horizontal surface, ambient temperature, humidity ratio and wind speed. The data used from all parameters except solar radiation were provided by a collaborator from Mali whereas the data for the solar radiation were obtained from NASA [8]. The data collected and used in simulations are shown in Table 3. It should be noted that Mali is located in one of the best zones with respect to the magnitude of solar radiation.

Table 3 Mean monthly weather data used in simulations

Month	Global radiation on horizontal (kJ/m ²)	Ambient air temperature (°C)	Relative humidity (%)	Wind speed (m/s)
Jan	17,820	35.8	47.0	1.7
Feb	21,132	36.0	36.5	1.8
Mar	24,552	37.3	32.9	2.6
Apr	26,100	39.7	63.9	1.8
May	26,712	38.4	76.7	1.3
Jun	25,308	35.8	89.0	1.0
Jul	24,408	33.0	96.0	0.8
Aug	23,688	32.0	97.8	0.8
Sep	23,184	33.4	98.7	0.8
Oct	21,852	35.2	93.7	0.5
Nov	19,152	37.6	71.5	0.6
Dec	17,208	35.1	58.3	1.3

5.2 Economic Analysis

A life cycle analysis is performed in order to obtain the total cost (or life cycle cost) and the life cycle savings (LCS) of the system. The economic scenario used in this project is that all the initial cost of the solar system is paid at the beginning. The period of economic analysis is taken as 20 years (life of the system). Electricity is assumed to be used for a fuel-only system. The economic analysis is performed within the TRNSYS environment.

In general, the present worth (or discounted cost) of an investment or cost C at the end of year N , at a discount rate of d and interest rate of i is obtained by:

$$PW_N = \frac{C(1+i)^{N-1}}{(1+d)^N} \quad (6)$$

In the case of this project, the various costs and savings are estimated annually. From the addition of fuel savings incurred because of the use of the system and the tax savings the mortgage, maintenance and parasitic costs are subtracted and thus the annual solar savings of the system are estimated which are converted into present worth values of the system. These are added up to obtain the life cycle savings according to the equation:

$$PW_{LCS} = \sum_{N=1}^N \frac{\text{Solar Savings}}{(1+d)^N} \quad (7)$$

The fuel savings are obtained by subtracting the annual cost of the conventional fuel used for the auxiliary energy from the fuel needs of a fuel only system. The integrated cost of the auxiliary energy use for the first year, i.e. solar back up, is given by the formula:

$$C_{aux} = \int_0^t C_{FA} Q_{aux} dt \quad (8)$$

The integrated cost of the total load for the first year i.e. cost of conventional fuel without solar, is:

$$C_{load} = \int_0^t C_{FL} Q_{load} dt \quad (9)$$

where C_{FA} and C_{FL} are the cost rates for auxiliary energy and conventional fuel respectively. If the same fuels are used for both then $C_{FA} = C_{FL}$. The investment cost of the stationary solar systems is estimated from:

$$C_s = C_f + C_a A \quad (10)$$

where C_f is the fixed cost and C_a is the area dependent cost. For the present work, $C_f = \$ 200$ and $C_a = 150 \text{ \$/m}^2$.

The maintenance cost is considered to be 1% of the initial investment and are assumed to increase at a rate of 1% per year of the system operation.

5.3 Results

A thermosyphon system, suitable for Mali, consists of one flat-plate collector panel 1.35m^2 in aperture area, a 150 lt hot water storage cylinder and the system is completed with 22mm piping connecting the solar collector with the storage. The performance of the system as given by TRNSYS is shown in Table 4. The monthly energy balance of the system is tabulated together with the total annual values.

Table 4 Monthly energy balance of the system (MJ)

MONTH	Q_{INS}	Q_U	HW_{LOAD}	Q_{AUX}	Q_{ENV}
Jan	896.8	628.5	592.0	57.25	86.5
Feb	911.5	605.1	535.2	21.19	91.3
Mar	1,083.0	668.8	561.3	5.98	115.4
Apr	1,014.0	605.8	497.9	1.96	113.0
May	993.2	549.0	436.6	0.98	116.0
Jun	880.8	461.1	362.1	5.45	106.2
Jul	892.0	446.1	343.0	11.73	114.8
Aug	917.6	447.8	327.4	10.85	127.4
Sep	946.2	475.7	347.0	6.65	131.6
Oct	1,016.0	568.6	452.2	8.14	124.2
Nov	926.5	581.5	497.9	15.68	103.3
Dec	882.8	610.1	576.9	52.79	89.5
YEAR	11,360	6,648	5,530	198.6	1,319

As can be seen from Table 4 such a system can provide 6,648 MJ of energy per year

The solar contribution is defined as:

$$f = \frac{HW_{LOAD} - Q_{AUX}}{HW_{LOAD}} \quad (11)$$

From the results presented in Table 4 the solar contribution is 0.96, i.e., 96% of the needs for hot water is satisfied with solar energy.

The financial characteristics of the system investigated give positive and very promising figures. By considering a rate for electricity equal to 0.16 US\$/kWh, the pay back time is 2 years and the life cycle savings, representing the money saved because of the use of the system throughout its life (20 years) instead of using conventional energy (electricity), is US\$ 2,200.

6. LIFE CYCLE ANALYSIS

The negative environmental impact of solar energy systems includes land displacement, and possible air and water pollution resulting from manufacturing, normal maintenance operations and demolition of the systems. However, land use is not a problem when collectors are mounted on the roof of a building, maintenance requirement is minimal and pollution caused by demolition is not greater than the pollution caused from demolishing a conventional system of the same capacity. The pollution created for the manufacture of the solar collectors is estimated by calculating the embodied energy invested in the manufacture and assembly of the collectors and estimating the pollution produced by this energy.

Initially the embodied energy of one solar collector panel, 1.35m² in area is determined. This is the same collector considered in the performance analysis of the systems. The analysis is based on the primary and intermediate embodied energy of the components and materials as illustrated in Fig. 4. In the present analysis no allowance is made for the unit packing, transportation and maintenance as these have insignificant contribution compared to the total.

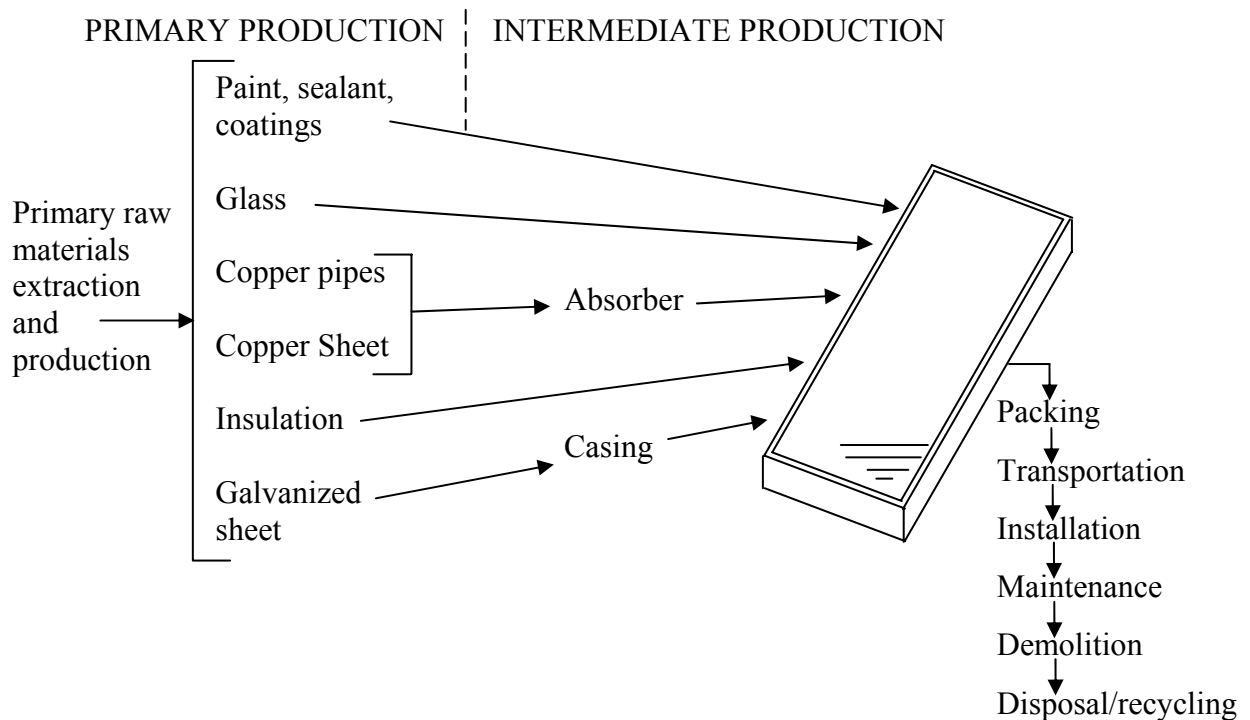

Fig. 4 Factors considered in the calculation of embodied energy of a flat-plate collector

The total embodied energy required to produce a complete flat-plate collector is calculated using primary and intermediate production stages. The primary stage is established from an assessment of the various materials used and their corresponding mass. Using the embodied energy index (MJ/kg) defined by Alcorn [9] the material embodied energy content within the unit is determined. Table 5 summarizes the unit materials used and lists their corresponding mass and embodied energy content. As can be seen from Table 5, the total embodied energy content for the production of one flat-plate collector panel is calculated at 2,663 MJ. This comprise the primary embodied energy of materials and the intermediate embodied energy, i.e., the amount of energy used in the production and assembly of the component parts during the construction stage and was determined through a stage-by-stage appraisal of the power sources used. Inherent within this intermediate stage is the fabrication of purchased components like screws, glass and insulation.

An analysis of the embodied energy content of a complete solar hot water system is shown in Table 6. It should be noted that only the extra components of the solar system are considered in this analysis as the other components are standard and are also present in the conventional system. As can be seen the total embodied energy for the complete system is 4,283 MJ.

Table 5 Embodied energy content of one flat-plate collector 1.35m² in area.

Description	Mass (kg)	Embodied energy index (MJ/kg)	Embodied energy content (MJ)
1.6x0.85x0.05m insulation	4.3	117	503.1
1.6x0.85x0.005m glass	9.5	15.9	151.1
1.8m, 22mm copper pipe	2.16	70.6	152.5
16m, 15mm copper pipe	9.9	70.6	698.8
2x1.05x0.005m galvanized steel sheet	8.2	34.8	285.4
5m rubber sealant	0.5	110	55
Black paint	0.3	44	13.2
Casing paint	0.9	44	39.6
20 No. screws	0.00125	34.8	Ignored
169x0.85x0.003m copper absorber	3.6	70.6	254.2
Total			2,153
Add 10% for contingencies			215
Unit manufacture using a net to gross value of conversion rate of 27%			295
Grant Total			2,663

Table 6 Embodied energy content for the construction and installation of the complete solar hot water system

Description	Mass (kg)	Embodied energy index (MJ/kg)	Embodied energy content (MJ)
Solar panel	-	-	2,663
4m, 22mm copper pipe	3.8	70.6	268.3
4m, pipe insulation	1	120	120
Steel frame	30	34.8	1,044
Total			4,095.3
Installation			187.7
Grant Total			4,283

The objective of this analysis is to compare the pollution created for the manufacture and installation of the solar system against its benefits due to the lower emissions realized during the operation of the systems. Therefore, for the life cycle assessment of the system considered the useful energy supplied by solar energy per year, shown in Table 4, is compared with the total embodied energy of the system shown in Table 6. As can be seen the total energy used in the manufacture and installation of the system is recouped in about 8 months, which is considered as very satisfactory.

7. CONCLUSIONS

In this paper a description of the constructional and thermal characteristics of thermosyphon units is presented followed by a study on the performance characteristics and environmental protection offered by the systems. A thermosyphon system, suitable for Mali, which is one of the best solar environments on earth, consists of one flat-plate collector panel 1.35m² in aperture area and a 150 lt hot water cylinder. The thermosyphon system is modeled with TRNSYS and simulated with the weather conditions of Bamako, Mali. The results show that such a system can provide 6,648 MJ of energy per year and the solar contribution is 0.96, i.e., 96% of the needs for hot water are satisfied with solar energy. By considering a rate for electricity equal to 0.16 US\$/kWh, the pay back time is 2 years and the life cycle savings, representing the money saved because of the use of the system throughout its life (20 years) instead of using conventional energy (electricity), is US\$ 2,200. With respect to the life cycle assessment, the pollution created for the production of the system is estimated by calculating the embodied energy invested in the manufacture, assembly and installation of the collectors and other parts of the system. For the present thermosyphon system the embodied energy is found to be equal to 4,283 MJ. By considering the useful energy collected by the system each year, the embodied energy is recouped in about 8 months. It can therefore be concluded that solar energy systems offer significant protection to the environment and cost savings and should be employed whenever possible in order to achieve a sustainable future.

REFERENCES

1. Rosen, M.A., 1996. The role of energy efficiency in sustainable development. *Technology and Society*, 15(4), pp. 21-26.
2. Dincer, I., Rosen, M.A., 1998. A worldwide perspective on energy, environment and sustainable development. *International Journal of Energy Research*, 22 (15), pp. 1305-1321.
3. <http://www.worldwatch.org/>
4. Dincer, I., 1999. Environmental impacts of energy, *Energy Policy*, 27(14), pp. 845-854.
5. Diakoulaki, D. Zervos, A., Sarafidis, J. and Mirasgedis, S., 2001. Cost Benefit Analysis for Solar Water Heating Systems, *Energy Conversion and Management*, Vol. 42, No. 14, pp. 1727-1739.
6. Kalogirou S., 2003. The Potential of Solar Industrial Process Heat Applications, *Applied Energy*, 76, pp. 337-361.
7. TRNSYS program manual. *University of Wisconsin*, 1996.
8. <http://eosweb.larc.nasa.gov/sse/retscreen/>
9. Alcorn J., 1995. Embodied energy coefficients of building materials. Centre for Building Performance Research. Victoria University of Wellington, New Zealand.